



Color Stand LED

user manual

©2018 ADJ PRODUCTS LLC all rights reserved. Information, specifications, diagrams, images, and instructions herein are subject to change without notice. ADJ logo and identifying product names and numbers herein are trademarks of ADJ PRODUCTS LLC. Copyright protection claimed includes all forms and matters of copyrightable materials and information now allowed by statutory or judicial law or hereinafter granted. Product names used in this document may be trademarks or registered trademarks of their respective companies and are hereby acknowledged. All non-ADJ brands and product names are trademarks or registered trademarks of their respective companies.

ADJ PRODUCTS LLC and all affiliated companies hereby disclaim any and all liabilities for property, equipment, building, and electrical damages, injuries to any persons, and direct or indirect economic loss associated with the use or reliance of any information contained within this document, and/or as a result of the improper, unsafe, insufficient and negligent assembly, installation, rigging, and operation of this product.

ADJ PRODUCTS LLC USA

6122 S. Eastern Ave. Los Angeles, CA. 90040
323-582-2650 | Fax 323-582-2941 | www.adj.com | info@adj.com

ADJ SUPPLY Europe B.V

Junostraat 2 6468 EW Kerkrade, The Netherlands
+31 (0)45 546 85 00 | Fax +31 45 546 85 99 | www.adj.eu | info@adj.eu

ADJ PRODUCTS GROUP Mexico

AV Santa Ana 30 Parque Industrial Lerma, Lerma, Mexico 52000
+52 (728) 282-7070 | ventas@adj.com

D O C U M E N T V E R S I O N

**An updated version of this document may be available online.
Please check www.adj.com for the latest revision/update of this document before beginning installation and use.**

Date	Document Version	Notes
------	------------------	-------

11/11/18	1	Initial release.
----------	---	------------------

FCC STATEMENT

This device complies with Part 15 of the FCC Rules. Operation is subject to the following two conditions: (1) this device may not cause harmful interference, and (2) this device must accept any interference received, including interference that may cause undesired operation.

FCC RADIO FREQUENCY INTERFERENCE WARNINGS & INSTRUCTIONS

This product has been tested and found to comply with the limits as per Part 15 of the FCC Rules. These limits are designed to provide reasonable protection against harmful interference in a residential installation. This device uses and can radiate radio frequency energy and, if not installed and used in accordance with the included instructions, may cause harmful interference to radio communications. However, there is no guarantee that interference will not occur in a particular installation. If this device does cause harmful interference to radio or television reception, which can be determined by turning the device off and on, the user is encouraged to try to correct the interference by one or more of the following methods:

- Reorient or relocate the device.
- Increase the separation between the device and the receiver.
- Connect the device to an electrical outlet on a circuit different from which the radio receiver is connected.
- Consult the dealer or an experienced radio/TV technician for help.

Energy Saving Matters (EuP 2009/125/EC)

Saving electric energy is a key to help protecting the environment. Please turn off all electrical products when they are not in use. To avoid power consumption in idle mode, disconnect all electrical equipment from power when not in use. Thank you!

CONTENTS

General Information	5
Limited Warranty (USA Only)	6
Safety Guidelines	7
Maintenance Guidelines	9
Overview	10
Installation Instructions	11
Remote Control	15
Trouble Shooting Tips	16
Frequently Asked Questions	16
Technical Specifications	17

GENERAL INFORMATION

INTRODUCTION

Please read and understand all instructions in this manual carefully and thoroughly before attempting to operate. These instructions contain important safety and use information.

UNPACKING

The products in this kit have been thoroughly tested and have been shipped in perfect operating condition. Carefully check the shipping carton for damage that may have occurred during shipping. If the carton appears to be damaged, carefully inspect each unit included for damage and be sure all accessories necessary to operate the units have arrived intact. In the event damage has been found or parts are missing, please contact our customer support team for further instructions. Please do not return this kit to your dealer without first contacting customer support at the number listed below. Please do not discard the shipping carton in the trash. Please recycle whenever possible.

WARRANTY RETURNS

All returned service items whether under warranty or not, must be freight pre-paid and accompany a return authorization (R.A.) number. The R.A. number must be clearly written on the outside of the return package. A brief description of the problem as well as the R.A. number must also be written down on a piece of paper and included in the shipping container. If the unit is under warranty, you must provide a copy of your proof of purchase invoice. Items returned without a R.A. number clearly marked on the outside of the package will be refused and returned at customer's expense. You may obtain a R.A. number by contacting customer support.

CUSTOMER SUPPORT

Contact ADJ Service for any product related service and support needs. Please visit forums.adj.com with questions, comments or suggestions.

ADJ SERVICE USA - Monday - Friday 8:00am to 4:30pm PST

800-322-6337 | Fax 323-582-2941 | support@adj.com

ADJ SERVICE EUROPE - Monday - Friday 08:30 to 17:00 CET

REPLACEMENT PARTS please visit parts.americandj.com

LIMITED WARRANTY (USA ONLY)

- A. ADJ Products, LLC hereby warrants, to the original purchaser, ADJ Products, LLC products to be free of manufacturing defects in material and workmanship for a prescribed period from the date of purchase (see specific warranty period on reverse). This warranty shall be valid only if the product is purchased within the United States of America, including possessions and territories. It is the owner's responsibility to establish the date and place of purchase by acceptable evidence, at the time service is sought.
- B. **For warranty service, you must obtain a Return Authorization number (RA#) before sending back the product—please contact ADJ Products, LLC Service Department at 800-322-6337.** Send the product only to the ADJ Products, LLC factory. All shipping charges must be pre-paid. If the requested repairs or service (including parts replacement) are within the terms of this warranty, ADJ Products, LLC will pay return shipping charges only to a designated point within the United States. If the entire instrument is sent, it must be shipped in its original package. No accessories should be shipped with the product. If any accessories are shipped with the product, ADJ Products, LLC shall have no liability whatsoever for loss of or damage to any such accessories, or for the safe return thereof.
- C. This warranty is void if the serial number has been altered or removed; if the product is modified in any manner which ADJ Products, LLC concludes, after inspection, affects the reliability of the product, if the product has been repaired or service by anyone other than ADJ Products, LLC factory unless prior written authorization was issued to purchaser by ADJ Products, LLC; if the product is damaged because not properly maintained as set forth in the instruction manual.
- D. This is not a service contract, and this warranty does not include maintenance, cleaning or periodic check up. During the period specified above, ADJ Products, LLC will replace defective parts at its expense with new or refurbished parts, and will absorb all expenses for warrant service and repair labor by reason of defects in material or workmanship. The sole responsibility of ADJ Products, LLC under this warranty shall be limited to the repair of the product, or replacement thereof, including parts, at the sole discretion of ADJ Products, LLC. All products covered by this warranty were manufactured after August 15, 2012, and bear identifying marks to that effect.
- E. ADJ Products, LLC reserves the right to make changes in design and/or improvements upon its products without any obligation to include these changes in any products theretofore manufactured.
- F. No warranty, whether expressed or implied, is given or made with respect to any accessory supplied with products described above. Except to the extent prohibited by applicable law, all implied warranties made by ADJ Products, LLC in connection with this product, including warranties of merchantability or fitness, are limited in duration to the warranty period set forth above. And no warranties, whether expressed or implied, including warranties of merchantability or fitness, shall apply to this product after said period has expired. The consumer's and/or Dealer's sole remedy shall be such repair or replacement as is expressly provided above; and under no circumstances shall ADJ Products, LLC be liable for any loss or damage, direct or consequential, arising out of the use of, or inability to use, this product.
- G. This warranty is the only written warranty applicable to ADJ Products, LLC Products and supersedes all prior warranties and written descriptions of warranty terms and conditions heretofore published.

LIMITED WARRANTY PERIODS

- **Non L.E.D. Lighting Products = 1-year (365 days) Limited Warranty** (Such as: Special Effect Lighting, Intelligent Lighting, UV lighting, Strobes, Fog Machines, Bubble Machines, Mirror Balls, Par Cans, Trussing, Lighting Stands etc. excluding LED and lamps)

- **Laser Products = 1 Year (365 Days) Limited Warranty** (excludes laser diodes which have 6 month limited warranty)
- **L.E.D. Products = 2-year (730 days) Limited Warranty** (excluding batteries which have a 180 day limited warranty) Note: 2 Year Warranty only applies to purchases within the United States
- **StarTec Series = 1 Year Limited Warranty** (excluding batteries which have a 180 day limited warranty).
- **ADJ DMX Controllers = 2 Year (730 Days) Limited Warranty**

S A F E T Y I N S T R U C T I O N S A N D G U I D E L I N E S

To guarantee a smooth operation, it is important to follow all instructions and guidelines in this manual. ADJ PRODUCTS LLC is not responsible for injury and/or damages resulting from the misuse of these devices due to the disregard of the information printed in this manual. Only qualified and/or certified personnel should perform installation of these devices and only the original rigging parts included with these devices should be used for installation. Any modifications to these devices and/or the included mounting hardware will void the original manufactures warranty and increase the risk of damage and/or personal injury.



THERE ARE NO USER SERVICEABLE PARTS INSIDE THESE DEVICES. DO NOT ATTEMPT ANY REPAIRS YOURSELF; DOING SO WILL VOID YOUR MANUFACTURES WARRANTY. DAMAGES RESULTING FROM MODIFICATIONS TO THESE DEVICES AND/OR THE DISREGARD OF SAFETY INSTRUCTIONS AND GUIDELINES IN THIS MANUAL VOID THE MANUFACTURES WARRANTY AND ARE NOT SUBJECT TO ANY WARRANTY CLAIMS AND/OR REPAIRS.



**NEVER SET UP OR INSTALL STAND ON UNEVEN SURFACE!
NEVER INSTALL OR MOUNT STAND IN UNSTABLE LOCATION!
SPREAD THE LEGS UNTIL THE STAYS EXTEND HORIZONTALLY!
NEVER REMOVE THE SAFETY PIN WHEN THE A KNOB IS LOOSE!
BE CAREFUL NOT TO OVEREXTEND THE INNER PIPE!
KEEP FLAMMABLE MATERIALS AWAY FROM THESE DEVICES!
MAX LOAD CAPACITY PER STAND IS 60 LBS. (27.2 KG)**



**INDOOR / DRY LOCATIONS USE ONLY!
DO NOT EXPOSE STAND TO RAIN AND/OR MOISTURE!**



WHEN USING STAND OUTISDE UNDER STRONG WIND, TAKE APPROPRIATE MEASURES TO PREVENT IT FROM FALLING DOWN!

TIGHTEN EACH KNOB AND BOLT SECURELY!



**NEVER LOOK DIRECTLY INTO THE LIGHT SOURCE!
RETINA INJURY RISK - MAY INDUCE BLINDNESS!
SENSITIVE PERSONS MAY SUFFER AN EPILEPTIC SHOCK!**

SAFETY INSTRUCTIONS AND GUIDELINES

DO NOT position stand close to any **FLAMMABLE MATERIALS** while operating.

DO NOT attempt installation and/or operation of stand without knowledge how to do so.

DO NOT permit operation by persons who are not qualified to operate these types of devices.

DO NOT shake stands, avoid brute force when installing and/or operating.

DO NOT operate these devices if the main power cord has become frayed, crimped and/or damaged. Replace any damaged power cords with a similar power rating.

DO NOT remove disassemble devices, there are NO user serviceable parts inside.

ALWAYS disconnect devices from main power source before performing any cleaning.

ALWAYS be sure to install these devices in an area that will allow proper ventilation.

Power cords should be safely routed and secured so they are not likely pinched.

Disconnect power cords during long periods of non-use.

Only use recommended rigging hardware as described in this guide.

Use the original packaging and materials to transport these devices in for service.

These devices should be serviced by qualified service personnel when:

- The power cords or plugs have become damaged.
- Objects have fallen on and/or liquid has spilled into the devices.
- The devices have been exposed to rain and/or moisture.
- The devices do not operate normally or exhibit a marked change in performance.

MAINTENANCE GUIDELINES



DISCONNECT POWER BEFORE PERFORMING ANY MAINTENANCE!

CLEANING

Frequent cleaning is recommended to insure proper function and an extended life. The frequency of cleaning depends on the environment in which the device operates in: damp, smoky or particularly dirty environments can cause greater accumulation of dirt on the stand or inner tube. Clean the external surface at least every 20 days with a soft cloth to avoid dirt/debris accumulation.

NEVER use alcohol, solvents, or ammonia-based cleaners.

MAINTENANCE

Regular inspections are recommended to insure proper function and extended life.

There are no user serviceable parts inside these devices, please refer all other service issues to an authorized ADJ service technician. Should you need any spare parts, please order genuine parts from your local ADJ dealer.

Please refer to the following points during routine inspections:

A detailed review by an approved electrical engineer every three months, to make sure the circuit contacts are in good condition and prevent overheating.

Be sure all screws and fasteners are securely tightened at all times. Loose screws may fall out during normal operation resulting in damage or injury as larger parts could fall.

Check for any deformations on the stand, stays, legs, knobs, inner pipe and T-bar. Deformations could allow for dust to enter into the devices. Damaged rigging points or unsecured rigging could cause the devices to fall and seriously injure a person(s).

Electric power supply cables must not show any damage, material fatigue or sediments.

OVERVIEW

INCLUDED ITEMS

- (1) Color Stand LED
- (1) RF Remote
- (1) Power Supply

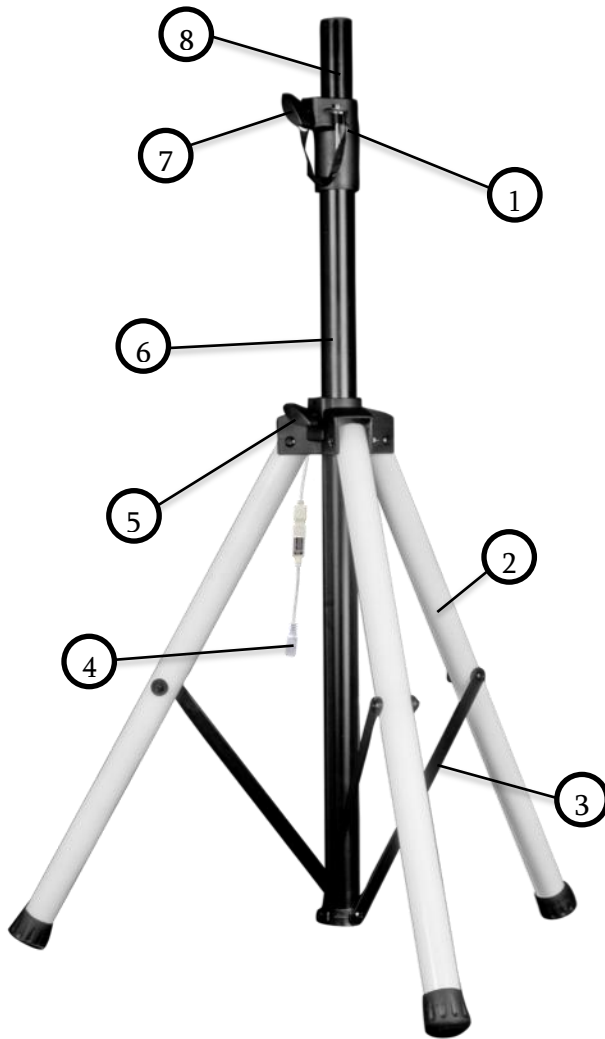

1. Safety Pin

2. Leg

3. Stay

4. Power Connection

5. Knob A

6. Lower Post

7. Knob B

8. Center Post

9. RF Remote

10. Power Supply

INSTALLATION INSTRUCTIONS



FLAMMABLE MATERIAL WARNING

Keep devices minimum 5.0 feet (1.5m) away from flammable materials and/or pyrotechnics.



ELECTRICAL CONNECTIONS

A qualified electrician should be used for all electrical connections and/or installations.



DO NOT INSTALL THE DEVICES IF YOU ARE NOT QUALIFIED TO DO SO!

BEFORE MOUNTING DEVICES, A PROFESSIONAL EQUIPMENT INSTALLER MUST BE CONSULTED.

AVOID INSTALLING OR MOUNTING THE UNIT IN UNSTABLE LOCATIONS, SUCH AS AN UNEVEN SURFACE OR MOVING TABLE. DOING SO MAY RESULT IN THE UNIT FALLING DOWN AND CAUSING PERSONAL INJURY AND/OR PROPERTY DAMAGE.

WHEN USING THE UNIT OUTSIDE UNDER STRONG WIND, TAKE APPROPRIATE MEASURES TO PREVENT IT FROM FALLING DOWN.

TIGHTEN EACH KNOB AND BOLT SECURELY. ENSURE THAT THE BRACKET HAS NO LOOSE KNOBS OR JOINTS AFTER INSTALLATION TO PREVENT ACCIDENTS AND OR INJURY.

AVOID PLACING THE UNIT IN A DOORWAY OR OTHER HIGH TRAFFIC AREAS AS PEOPLE MAY TRIP ON THE EQUIPMENT AND CORDS, OR BE INJURED BY FALLING OBJECTS.

FOR ADDED PROTECTION, MOUNT DEVICES IN AREAS OUTSIDE WALKING PATHS, SEATING AREAS, OR IN AREAS WERE UNAUTHORIZED PERSONNEL CAN REACH THE DEVICES.

TAKE CARE NOT TO PINCH YOUR FINGERS OR HANDS BETWEEN THE STAND LEGS.

NEVER STAND DIRECTLY BELOW THE DEVICES WHEN MOUNTING, REMOVING OR SERVICING.

DEVICES MUST ALL BE INSTALLED FOLLOWING ALL LOCAL, NATIONAL, AND COUNTRY COMMERCIAL ELECTRICAL AND CONTRUCTION CODES AND REGULATIONS.

DO NOT EXCEED WEIGHT CAPACITY OF 60 LBS. (27.2 KG)

INSTALLATION (continued)

SETUP

Loosen Knob A by turning it counter clockwise. Spread the legs by pulling up on the lower post until the stays extend horizontally.



Loosen Knob B by turning it counter clockwise. Extend the center post to the desired height and insert the safety pin through the stopper holes in the center post. Secure and tighten Knob A by turning it clockwise.



MOUNTING THE SPEAKER WITHOUT A BRACKET

If the speaker (sold separately) has a pole mount socket located on the bottom of the speaker, place the speaker on top of the stand by lowering the speaker onto the center post. Ensure that center post fits securely into pole mount socket.

Note: Due to differences in speaker size, weight and mounting height, be sure at least two persons are available to install the speaker. Failure to do so could result in personal injury.



MOUNTING THE SPEAKER WITH A BRACKET

If the speaker (sold separately) has a bracket for mounting, install the bracket onto the speaker before placing the speaker on top of the stand. Lower the speaker bracket onto the center post. Ensure that center post fits securely into speaker mounting bracket.

If additional adjustments are required for the mounting bracket or aiming the speaker, please refer to the instructions provided with the bracket.

Note: Due to differences in speaker size, weight and mounting height, be sure at least two persons are available to install the speaker. Failure to do so could result in personal injury.



**Speaker not included.*

CONNECTING THE POWER

The Color Stand LED has a 12V, 3A power supply included. To connect the power, connect the power supply to the adapter at the mid section of the stand (see photo below).



REMOTE CONTROL

PAIRING: The original remote that comes in the box is already paired to the unit. In the event that the remote is not paired with the unit, or if pairing to an additional unit, follow the steps below:

- 1) Unplug the power to the main unit and reconnect the power after ten seconds.
- 2) Press the “SPEED –“ and “SPEED +” keys together within 5 seconds of reconnecting the power.

CHANGE OUTPUT COLOR SEQUENCE: The default output color sequence is: Green, Red, and Blue. If for any reason, the unit is displaying a different sequence, or the Direct Color Select keys do not match, the unit can be reconfigured by following the steps below:

- 1) Unplug the power to the main unit and reconnect the power after ten seconds.
- 2) Press the “RED” and “Blue” keys together within 5 seconds of powering the unit on.
 - a. The unit will toggle between 6 color combinations and the sequence will be memorized.

POWER

Turns the unit ON and restores the unit to previous status. If the unit is on, the unit will enter standby mode.

DEMO

Play 17 dynamic modes in a loop. Each mode repeats 3 times.

MODE +/-

This button lets you cycle through color fade mode, color change mode, and auto run modes. Each press of the button will change to the next mode. There are 22 different programs. You can use the “+” and “-” buttons to cycle through the 22 programs.

SPEED +/-

There are 10 speeds to choose from. Select the speed using the “SPEED +” or “SPEED –“ button.

COLOR +/-

There are 20 colors to choose from. Select the color using the “COLOR +” or “COLOR –“ button.

BRIGHT +/-

There are 5 brightness levels to choose from. Adjust the brightness using the “BRIGHT +” or “BRIGHT –“ button.

DIRECT COLOR SELECT BUTTONS

There are 7 shortcut keys. Each key represents a static color. These colors are also included in COLOR +/- selections.



TROUBLE SHOOTING TIPS

The stand seems unstable.

1. Check to ensure that all knobs and hardware are tight and secure.
2. If the stand is in an unsuitable location (uneven or unstable surface), reposition the stand.
3. Additional measures (i.e. sandbags or security cables) may be needed to secure the stand.

The speaker does not stay at the desired height.

1. Check to ensure that all knobs and hardware are tight and secure.
2. Check to ensure that the safety pin is installed and is being used.

FREQUENTLY ASKED QUESTIONS

Listed below are a few answers to common questions users may have.

1. What diameter is the inner pipe?

The pipe diameter is 1.38 inches. (35 mm)

2. What is weight capacity of the speaker stand?

Each stand has a weight capacity of 60 lbs. (27.2 kg)

3. Is this DMX compatible?

No, the Color Stand LED does not use DMX.

4. What is the maximum height of the stand?

The maximum recommended height is 73.68 inches (1,871.5 mm).

5. Are additional stands available?

Yes. A variety of stands and accessories are available at www.adj.com.

OPTIONAL ACCESSORIES

Order Code	Description
EVE100	Single sided white speaker stand scrim. 5 ft. Includes a carrying bag
EVE200	2 sided white speaker stand scrim. 5 ft. Includes a carrying bag
EVE300	3 sided white speaker stand scrim. 5 ft. Includes a carrying bag
OSL587	O Slim 2 Clamp (Pearl)
OSL150	O Slim 1.5 Clamp

TECHNICAL SPECIFICATIONS

Total Height Range: 43.2 inches (1,097.3 mm) to 73.68 inches (1,871.5 mm)

Includes: Color Stand LED, IR remote and 12V power supply

Load Capacity: 60 lbs. (27.2 kg)

Material: Steel + PVC

Power: AC100-240V 50/60Hz

Modes: 22 Dynamic Modes

Colors: 20 Static Colors

Speed: Variable Speeds

Brightness: 5 Levels

Remote Distance: Up to 49 feet (15 m)

DIMENSIONS

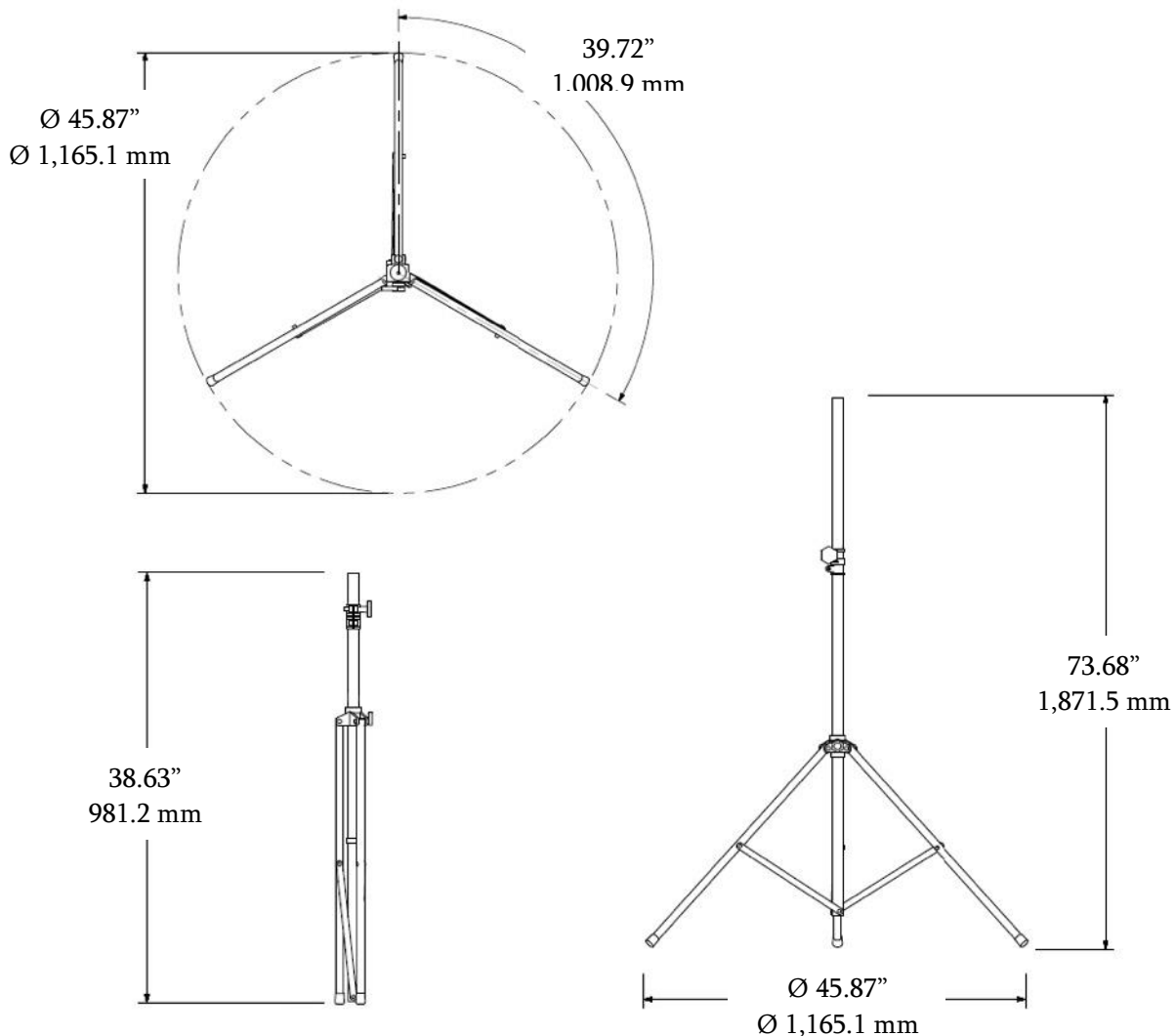

Total Height Range: 43.2" (1,097.3 mm) to 73.68" (1,871.5 mm).

Specifications subject to change without any prior written notice.

